

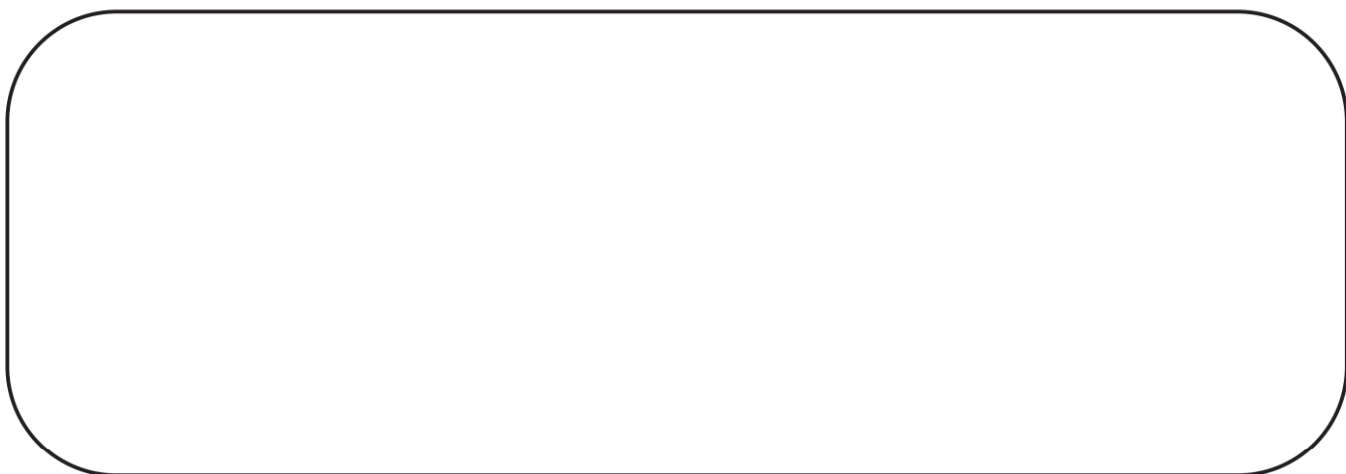

BUILT-IN COOKING HOBS



Installation advices - Instructions for the use
KEEP IN A SAFE PLACE

Before operating this appliance,
please read these instructions carefully

Dear Customer,

Thank you for having purchased and given your preference to our product.

The safety precautions and recommendations reported below are for your own safety and that of others. They will also provide a means by which to make full use of the features offered by your appliance.

Please preserve this booklet carefully. It may be useful in future, either to yourself or to others in the event that doubts should arise relating to its operation.

This appliance must be used only for the task it has explicitly been designed for, that is for cooking foodstuffs. Any other form of usage is to be considered as inappropriate and therefore dangerous.

The manufacturer declines all responsibility in the event of damage caused by improper, incorrect or illogical use of the appliance.

IMPORTANT SAFETY PRECAUTIONS AND RECOMMENDATIONS

IMPORTANT: This appliance is designed and manufactured solely for the cooking of domestic (household) food and is not suitable for any non domestic application and therefore should not be used in a commercial environment.

The appliance guarantee will be void if the appliance is used within a non domestic environment i.e. a semi commercial, commercial or communal environment.

Read the instructions carefully before installing and using the appliance.

- This appliance has been designed and manufactured in compliance with the applicable standards for the household cooking products and it fulfills all the safety requirements shown in this manual, including those for surface temperatures.
Some people with sensitive skin may have a more pronounced temperature perception with some components although these parts are within the limits allowed by the norms.
The complete safety of the appliance also depends on the correct use, we therefore recommend to always pay a extreme attention while using the product, especially in the presence of children.
- After having unpacked the appliance, check to ensure that it is not damaged.
In case of doubt, do not use it and consult your supplier or a professionally qualified technician.
- Packing elements (i.e. plastic bags, polystyrene foam, nails, packing straps, etc.) should not be left around within easy reach of children, as these may cause serious injuries.
- Some appliances are supplied with a protective film on steel and aluminium parts. **This film must be removed before using the appliance.**
- **IMPORTANT:** The use of suitable protective clothing/gloves is recommended when handling or cleaning this appliance.

- Do not attempt to modify the technical characteristics of the appliance as this may become dangerous to use. The manufacturer declines all responsibility for any inconvenience resulting from the inobservance of this condition.
- CAUTION: this appliance must only be installed in a permanently ventilated room in compliance with the applicable regulations.
- Do not carry out cleaning or maintenance operations on the appliance without having previously disconnected it from the electric power supply.
- Do not use a steam cleaner because the moisture can get into the appliance therefore making it unsafe.
- Do not touch the appliance with wet or damp hands (or feet).
- Do not use the appliance whilst in bare feet.
- If you should decide not to use this appliance any longer (or decide to substitute another model), before disposing of it, it is recommended that it be made inoperative in an appropriate manner in accordance to health and environmental protection regulations, ensuring in particular that all potentially hazardous parts be made harmless, especially in relation to children who could play with unused appliances.
- The various components of the appliance are recyclable. Dispose of them in accordance with the regulations in force in your country. If the appliance is to be scrapped, remove the power cord.
- After use, ensure that the knobs are in the off position.
- Children less than 8 years of age shall be kept away unless continuously supervised.
- This appliance can be used by children aged from 8 years and above and persons with reduced physical, sensory or mental capabilities or lack of experience and knowledge if they have been given supervision or instruction concerning use of the appliance in a safe way and understand the hazards involved. Children shall not play with the appliance. Cleaning and user maintenance shall not be made by children without supervision.

- The manufacturer declines all liability for injury to persons or damage to property caused by incorrect or improper use of the appliance.
- **WARNING:** During use the appliance and its accessible parts become hot; they remain hot for some time after use.
 - Care should be taken to avoid touching heating elements on the hob.
 - To avoid burns and scalds, young children should be kept away.
- Make sure that electrical cables connecting other appliances in the proximity of the cooktop cannot come into contact with the hob.
- **WARNING:** Unattended cooking on a hob with fat or oil can be dangerous and may result in fire. **NEVER** try to extinguish a fire with water, but switch off the appliance and then cover flame e.g. with a lid or a fire blanket.
- **WARNING:** Danger of fire: do not store items on the cooking surfaces.
- **WARNING:** If the hob is cracked or otherwise damaged by falling objects etc., disconnect the appliance from the electrical power supply to avoid the possibility of electric shock and call Customer Service.
- **WARNING:** When correctly installed, your product meets all safety requirements laid down for this type of product category. However special care should be taken around the underneath of the appliance as this area is not designed or intended to be touched and may contain sharp or rough edges, that may cause injury.
- **CAUTION:** The cooking process has to be supervised. A short term cooking process has to be supervised continuously.
- If the power supply cable is damaged, it must be replaced only by an authorized service agent in order to avoid a hazard.
- If the appliance is not fitted with a supply cord and a plug, or with other means for disconnection from the supply mains having a contact separation in all poles that provide full disconnection under

overvoltage category III conditions, means for disconnection must be incorporated in the fixed wiring in accordance with the wiring rules.

- **WARNING:** The appliance and its accessible parts become hot during use.
Care should be taken to avoid touching heating elements.
Children less than 8 years of age shall be kept away unless continuously supervised.
- **WARNING:** Use only hob guards designed by the manufacturer of the cooking appliance or indicated by the manufacturer of the appliance in the instructions for use as suitable or hob guards incorporated in the appliance. The use of inappropriate guards can cause accidents.

Advice for the installer

IMPORTANT

- The appliance should be installed, regulated and adapted to function by a **QUALIFIED INSTALLATION TECHNICIAN**.
- Failure to comply with this condition will render the guarantee invalid.
- The appliance must be installed in compliance with the regulations in force in your country and in observation of the manufacturer's instructions.
- Installation technicians must comply to current laws in force concerning ventilation and the evacuation of exhaust gases.
- Always disconnect the appliance from the electrical supply before carrying out any maintenance operations or repairs.
- **The appliance must be housed in heat-resistant units.**
- **These tops are designed to be embedded into kitchen fixtures measuring 600 mm in depth.**
- **The walls of the units must not be higher than work top and must be capable of resisting temperatures of 105 °C above room temperature.**
- **Do not install the appliance near inflammable materials (eg. curtains).**

WARNING

When correctly installed, your product meets all safety requirements laid down for this type of product category.

However special care should be taken around the underneath of the appliance as this area is not designed or intended to be touched and may contain sharp or rough edges, that may cause injury.

1 INSTALLATION

Cooking hobs 4 GAS or 3 GAS + 1 ELECTRIC HOTPLATE

TECHNICAL INFORMATION FOR THE INSTALLER

In order to install the cooker top into the kitchen fixture, a hole with the dimensions shown in fig. 1.2 has to be made, bearing in mind the following:

- within the unit, between the bottom of the cooktop and the upper surface of a shelf there must be a clearance of at least 30 mm;
- the cooker top must be kept no less than 100 mm away from any side wall (fig. 1.2);
- the hob must be installed at least 35 mm from the wall;
- there must be a distance of at least 650 mm between the hob and any wall cupboard or extractor hood positioned immediately above (see fig. 1.1);
- If the hob is not installed over a built-in oven it is essential to install a heat baffle between the bottom of the hob and the underlying unit;
- if the hob is installed over a built-in oven, there must be a distance of at least 30 mm between the two appliances. The two appliances shall be connected to the gas /electrical supply with independent connections.

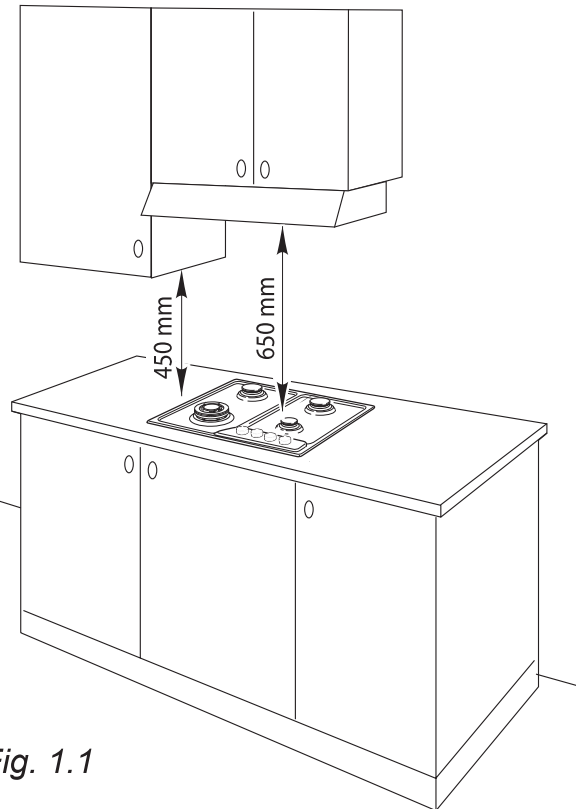

Fig. 1.1

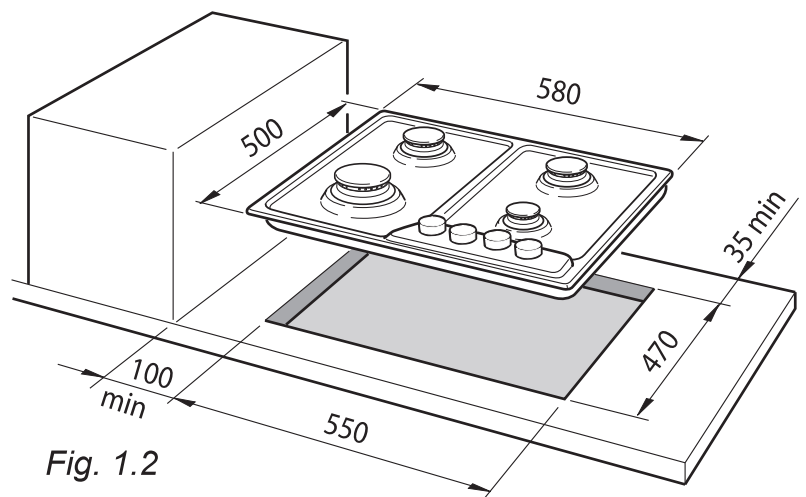

Fig. 1.2

Models with triple ring burner: It is absolutely essential that you place a separator between the base of the hob and the drawer unit.

Cooking hobs with 4 ELECTRIC HOTPLATES

TECHNICAL INFORMATION FOR THE INSTALLER

In order to install the cooker top into the kitchen fixture, a hole with the dimensions shown in fig. 1.4 has to be made, bearing in mind the following:

- within the unit, between the bottom of the cooktop and the upper surface of a shelf there must be a clearance of at least 30 mm;
- the cooker top must be kept no less than 50 mm away from any side wall (fig. 1.4);
- the hob must be installed at least 65 mm from the wall;
- there must be a distance of at least 650 mm between the hob and any wall cupboard or extractor hood positioned immediately above (see fig. 1.5).

Notice: if an oven is installed under the hob, it must have a forced air convection cooling system. The natural air ventilation canals shown in fig. 1.3 must allow the hob to cool properly.

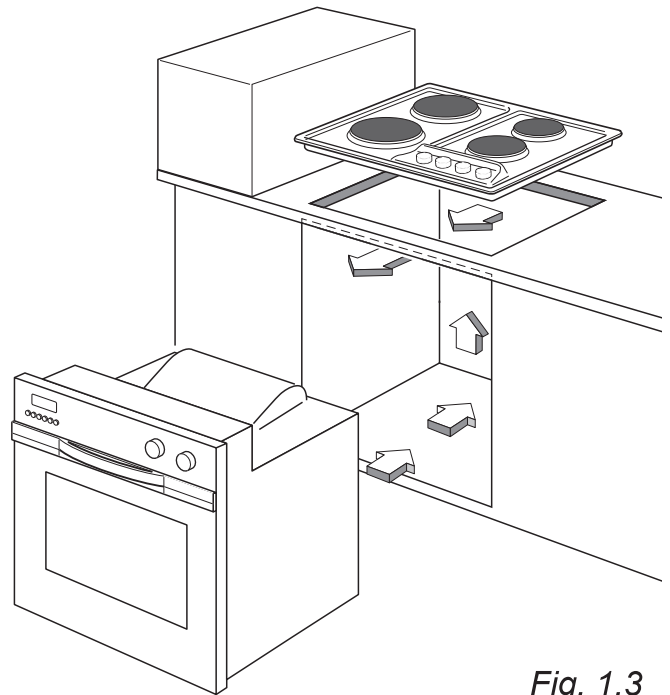

Fig. 1.3

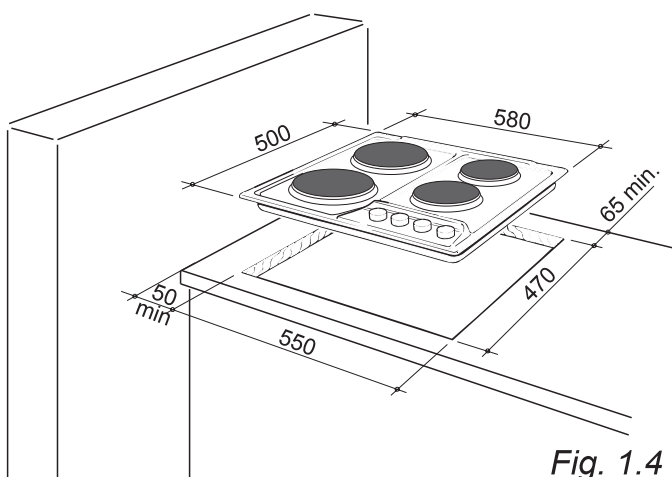

Fig. 1.4

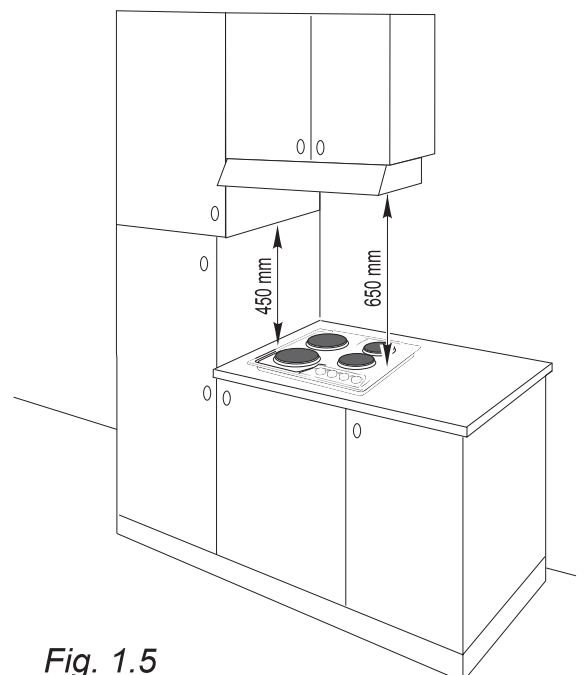

Fig. 1.5

INSTALLATION IN KITCHEN

CABINET WITH DOOR (fig. 1.6)

It is recommended that a 30mm clearance be left between to base of the cooktop and the separator.

The separator shall be heat resistant, made of low thermal conductivity material and shall be removable with the use of a tool for installation and service.

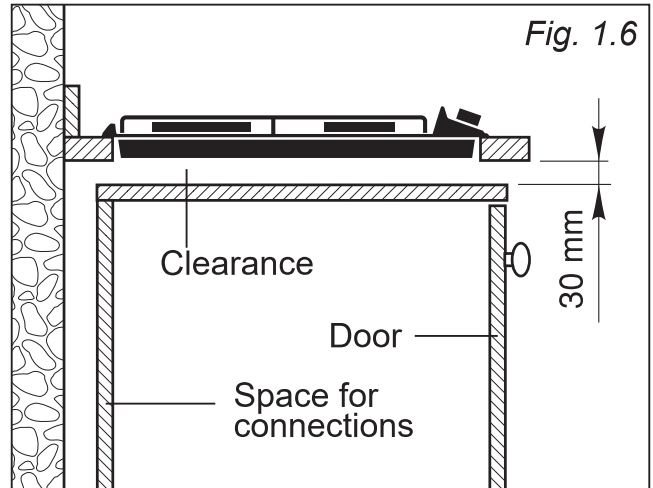

FASTENING THE COOKTOP (fig. 1.7)

Each cooktop is provided with an installation kit including brackets and screws for fastening the top to fixture panels from 2 to 4 cm thick.

- Cut the unit.
- Stretch gasket "D" over the edge of the hole made, being careful to overlay the junction edges. Turn the cooktop over and put tabs "A" into the mountings, only tighten screws "B" a few turns.
Make sure that the tabs are mounted correctly as shown in the figure 1.7.
Turn the tabs so that the cooktop can be put into the hole.
- Put the cooktop into the hole cut into the unit and position it correctly.
- Put tabs "A" into place, tooth "C" of the tabs should go into the hole.
- Tighten screws "B" until the cooktop is completely secured.
- Using a sharp tool cut off the part of gasket "D" which protrudes from the cooktop.
Take care not to damage the benchtop.

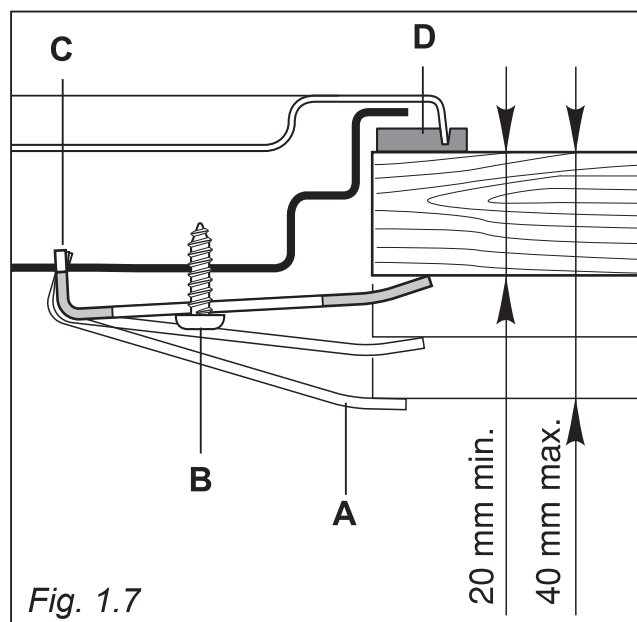

VENTILATION REQUIREMENTS

The appliance must be installed in compliance with applicable local regulations concerning ventilation and the evacuation of exhaust gases.

Intensive and prolonged use may require extra ventilation, e.g. opening a window, or more efficient ventilation increasing the mechanical suction power if this is fitted.

CHOOSING SUITABLE SURROUNDINGS

The room where the gas appliance is to be installed must have a natural flow of air so that the gas can burn (in compliance with applicable local regulations).

The flow of air must come directly from one or more openings made in the outside walls with a free area of at least 100 cm² (or refer to applicable local regulations).

If the appliance does not have a no-flame safety device this opening must have an area of at least 200 cm² (or refer to applicable local regulations).

The openings should be near the floor and preferably on the side opposite the exhaust for combustion products and must be made so that they cannot be blocked from either the inside or the outside.

When these openings cannot be made, the necessary air can come from an adjacent room which is ventilated as required, as long as it is not a bed room or a danger area (in compliance with applicable local regulations).

In this case, the kitchen door must allow the passage of the air.

DISCHARGING PRODUCTS OF COMBUSTION

Extractor hoods connected directly to the outside must be provided, to allow the products of combustion of the gas appliance to be discharged (fig. 1.8).

If this is not possible, an electric fan may be used, attached to the external wall or the window; the fan should have a capacity to circulate air at an hourly rate of 3-5 times the total volume of the kitchen (fig. 1.9).

The fan can only be installed if the room has suitable vents to allow air to enter, as described under the heading "Choosing suitable surroundings".

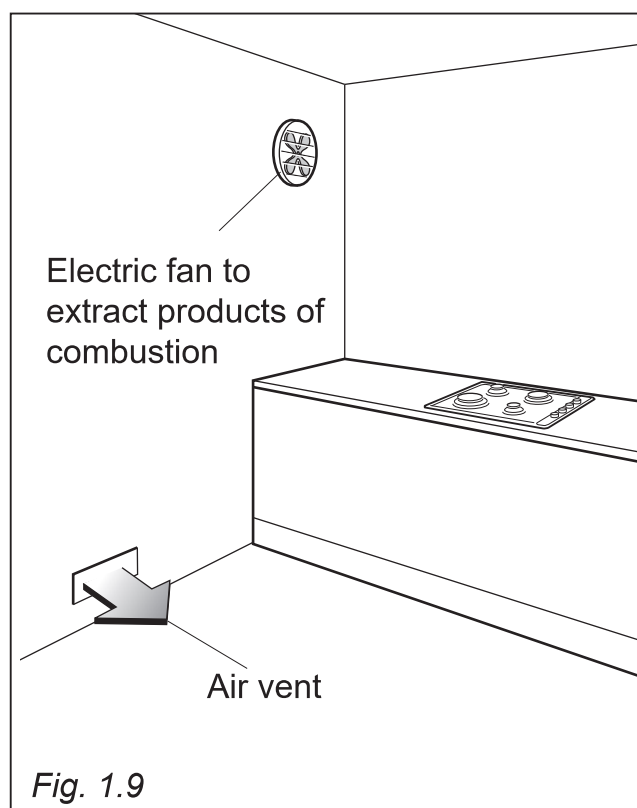
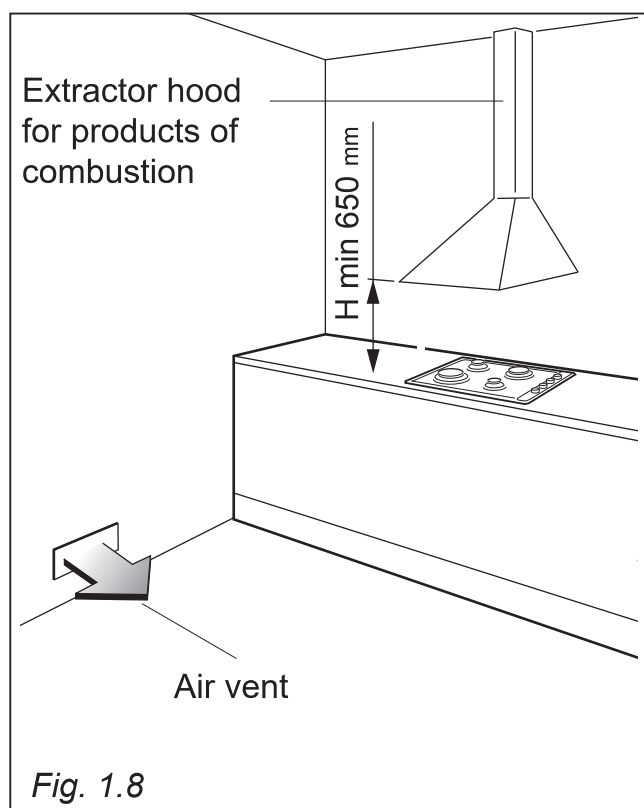

2 GAS SECTION

GAS INSTALLATION REQUIREMENTS

Important !

- This appliance must be installed and serviced only by a suitably qualified, registered installer. The installer shall refer to the local standards in force.
- Failure to install the appliance correctly could invalidate any manufacturer's warranty.
- Before installation, make sure that the local distribution conditions (gas type and pressure) and the adjustment of this appliance are compatible. The appliance adjustment conditions are given on the plate or the label.
- If the gas pressure (for which the appliance is to be used) is variable or if it is not within the values indicated on the rating plate, it is mandatory to install a proper gas pressure regulator which must be adjusted to guarantee the correct operating pressure to the appliance (as per rating plate).
The regulator must be installed, adjusted and tested by a qualified technician.
- **WARNING:** Using the appliance with a wrong and/or variable gas pressure may be extremely dangerous and may result in serious injury to the user. Damage to the appliance could occur if not observing this condition.
The manufacturer declines every responsibility for any inconvenience resulting from the inobservance of this condition.

This appliance is supplied for use on LPG (check the gas regulation label attached on the appliance).

OR

This appliance is supplied for use on Natural gas or LPG (check the gas regulation label attached on the appliance).

- Appliances supplied for use on Natural gas: they are adjusted for this gas only and cannot be used on any other gas (LPG) without modification. The appliances are manufactured for conversion to LPG.
- Appliances supplied for use on LPG: they are adjusted for this gas only and cannot be used on any other gas (Natural gas) without modification. The appliances are manufactured for conversion to Natural gas.

If the Natural gas/LPG conversion kit is not supplied with the appliance this kit can be purchased by contacting the After-Sales Service.

FOR SOUTH AFRICA ONLY

**The appliance is predisposed and adjusted to operate with the gas G30/G31 (LPG USE).
Operating pressure: 2,8 kPa.**

This appliance is manufactured for conversion to G20 (NATURAL GAS) if required and is supplied with a conversion kit.

This appliance must only be connected to NATURAL GAS after a NATURAL GAS conversion kit has been fitted.

CONNECTING THE COOKTOP TO THE GAS SUPPLY

The gas connection fitting (fig. 2.1) is made up of:

- the floating nut;
- the elbow;
- the gaskets;

The gas connection must be carried out by an authorised person according to the relevant local standards.

- If using a flexible hose, make sure it does not come into contact with moving parts.
- The rear of the chassis is recessed to provide a channel for the appliance inlet pipe.
- The gas connection fitting can be turned in the direction required (but never in a vertical or horizontal position) after loosening the elbow and floating nut connection.
- Never attempt to turn the elbow without having first loosened the floating nut.
- The supplied gaskets guarantee a good seal for the gas connection. We recommend that you replace the gaskets on the slightest sign of wear, deformation or imperfection.
- After connecting to the gas mains, check that the couplings are correctly sealed, using soapy solution, but never a naked flame.

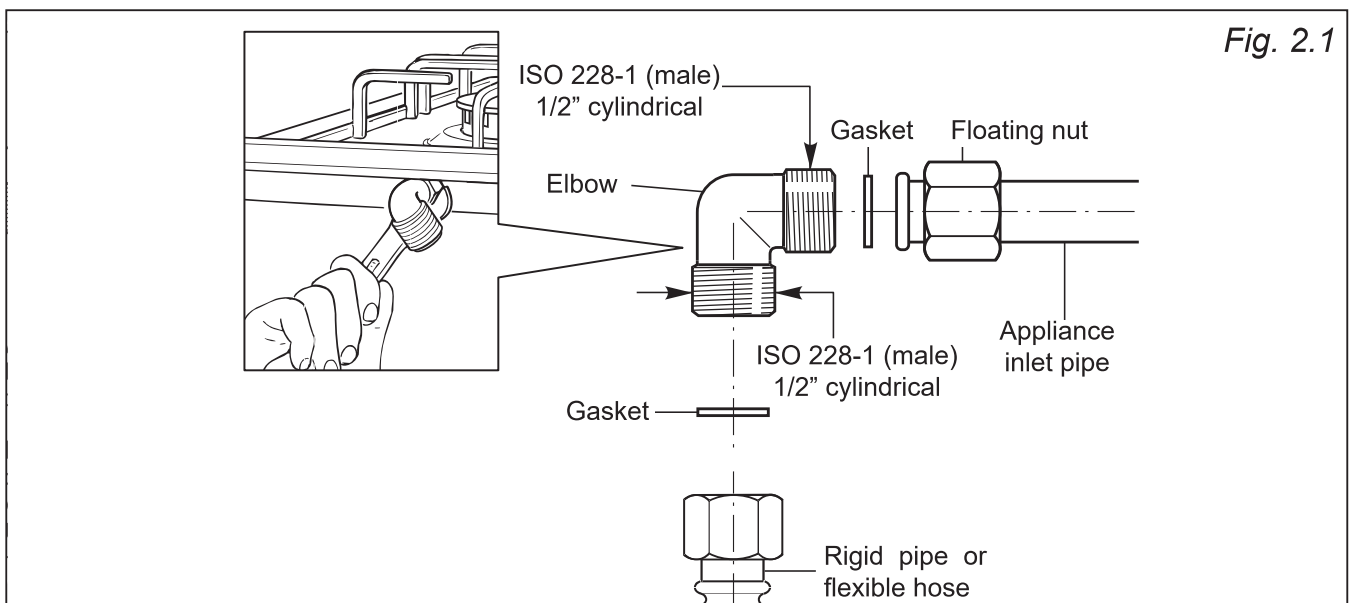

ADDITIONAL GAS CONNECTION REQUIREMENTS

When connecting the cooktop to the gas supply with rigid pipes or a flexible hose, make sure that:

- You use rigid pipes or a flexible hose compliant with applicable local regulations. The flexible hose shall be of the correct construction for the type of gas being used and of the correct size to maintain the heat output of the appliance.
- The connection with rigid metal pipes does not cause stress or pressure to the gas piping.
- The flexible hose is not under tension, twisted, kinked, or too tightly bent, neither while the cooktop is in use nor while it is being connected or disconnected.
- The flexible hose is not longer than 2000 mm (or refer to applicable local regulations) and does not come into contact with sharp edges, corners, or moving parts, as these may cause abrasion. Use a single flexible hose only; never connect the cooktop with more than one flexible hose.
- The flexible hose can easily be inspected along its entire length to check its condition; if it has an expiry date, it should be replaced before that date.
- If using a flexible hose which is not entirely made of metal, make sure that it does not come into contact with any part of the cooktop with a surface temperature of 70°C or above (or refer to applicable local regulations).
- The rigid pipe or flexible hose is replaced if it shows signs of damage.
- The flexible hose is not subject to excessive heat by direct exposure to flue products or by contact with hot surfaces.
- The socket into which the plug of the flexible hose fit is permanently attached to a firmly fixed gas installation pipe and is positioned so that the hose hangs freely downwards.
- The plug of the flexible hose is accessible after installation, so that it can be disconnected for service or removal.
- You inform the customer that the rigid pipe or flexible hose should not be subjected to corrosion by cleaning agents.

GAS MAINTENANCE

Some models - for the gas category check the data label attached on the appliance

TABLE FOR THE CHOICE OF THE INJECTORS			
Cat: I 3+			G30/G31 28-30/37 mbar
BURNERS	Nominal Power [kW]	Reduced Power [kW]	Ø injector [1/100 mm]
Auxiliary (A)	1,00	0,40	50
Semi-rapid (SR)	1,75	0,45	66
Rapid (R)	3,00	0,75	87
Triple-ring (TR)	3,50	1,50	93

Some models - for the gas category check the data label attached on the appliance

TABLE FOR THE CHOICE OF THE INJECTORS				
Cat: II 2H 3+			G30/G31 28-30/37 mbar	G20 20 mbar
Cat: II 2E 3+			G30/G31 28-30/37 mbar	G20/G25 20/25 mbar
BURNERS	Nominal Power [kW]	Reduced Power [kW]	Ø injector [1/100 mm]	Ø injector [1/100 mm]
Auxiliary (A)	1,00	0,40	50	77
Semi-rapid (SR)	1,75	0,45	66	101
Rapid (R)	3,00	0,75	87	129
Triple-ring (TR)	3,50	1,50	93	135

AIR VENT NECESSARY FOR GAS COMBUSTION = (2 m ³ /h x kW)	
BURNERS	Air necessary for combustion [m ³ /h]
Auxiliary (A)	2,00
Semi-rapid (SR)	3,50
Rapid (R)	6,00
Triple-ring (TR)	7,00

LUBRICATION OF THE GAS TAPS

In case of difficulty in the gas taps operation, call Service.

IMPORTANT

All intervention regarding installation, maintenance and conversion of the appliance must be fulfilled with original factory parts.

The manufacturer declines any liability resulting from the non-compliance of this obligation.

REPLACEMENT OF THE INJECTORS

Select the injectors to be replaced according to the “Table for the choice of the injectors”.

The nozzle diameters, expressed in hundredths of a millimetre, are marked on the body of each injector.

If the injectors are not supplied they can be obtained from the “Service Centre”.

Auxiliary,
semi-rapid
and rapid
burners

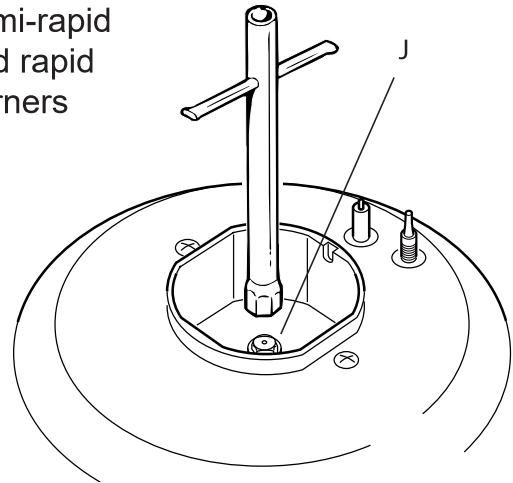

Fig. 2.2

REPLACEMENT OF THE INJECTORS OF THE COOKTOP BURNERS

To replace the injectors proceed as follows:

- Remove pan supports and burners from the cooktop.
- Using a wrench, substitute the nozzle injectors “J” (figs. 2.2, 2.3) with those most suitable for the kind of gas for which it is to be used.

The burners are conceived in such a way so as not to require the regulation of the primary air.

Triple-ring
burner

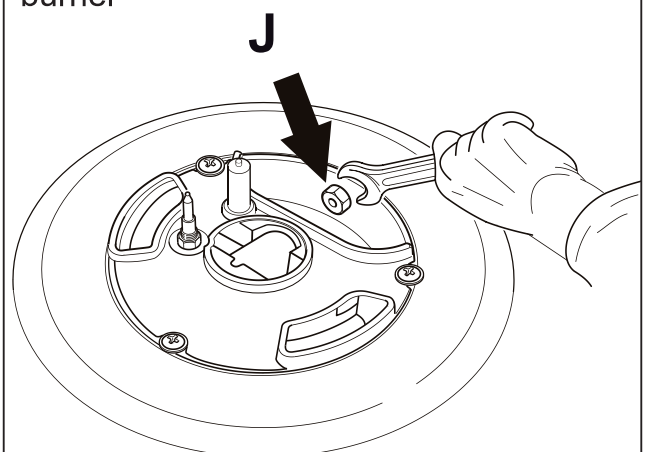

Fig. 2.3

ADJUSTING OF THE MINIMUM OF THE TOP BURNERS

In the minimum position the flame must have a length of about 4 mm and must remain lit even with a quick turn from the maximum position to that of minimum.

The flame adjustment is done in the following way:

- Turn on the burner.
- Turn the tap to the MINIMUM position.
- Take off the knob.
- With a small flat screwdriver turn the screw "A" to the correct regulation (figs. 2.4a or 2.4b).

Normally for G30/G31 (LPG), the regulation screw is tightened up.

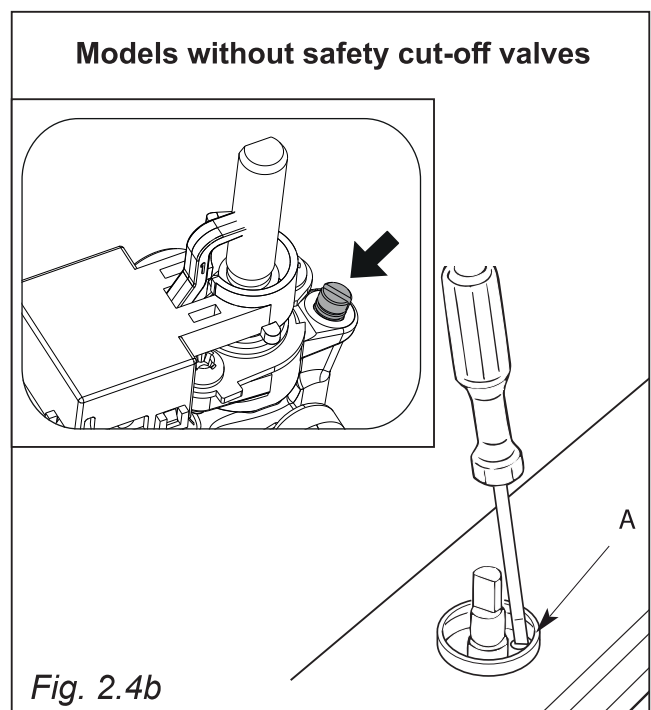
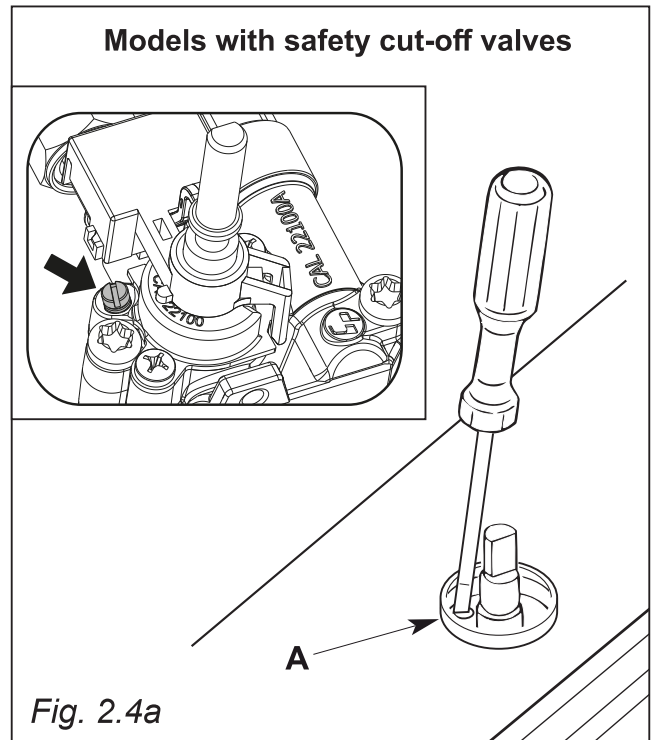

3 ELECTRICAL SECTION

IMPORTANT: The appliance must be installed by a qualified technician according with the current local regulations and in compliance with the manufacturer instructions. Incorrect installation might cause harm and damage to people, animals or objects, for which the manufacturer accepts no responsibility.

Connection to a good earth wiring system is absolutely essential.

The manufacturer accepts no responsibility for any inconvenience caused by failure to comply with this rule.

Before carrying out any work on the electrical section of the appliance, it must be disconnected from the mains.

DETAILS

- Connection to the electric power supply must be carried out by a qualified technician and following the appropriate safety regulations;
- Before carrying out the connection to the power supply, the voltage rating of the appliance (stamped on the appliance identification plate) must be checked for correspondence to the available mains supply voltage, and the mains electric wiring should be capable of handling the hob's power rating (also indicated on the identification plate);
- The power supply cord must not touch against any hot surfaces and must be placed so that its temperature does not exceed 75°C at any point along its length.
- Once the appliance has been installed, the switch or socket must always be accessible.
- The appliance must have its own supply; any other appliances installed near it must be supplied separately.
- **N.B. For connections to the mains power supply, never use adapters, reductions or multiple power points as these may overheat and catch fire.**
- **If the hob surface is cracked disconnect the appliance from the mains and contact the After-Sales Service.**

In the event that installation should require modifications to the mains supply wiring system or if the power plug is not suitable for the type of power point available, it is recommended that a qualified technician be called to carry out substitution.

The technician will also have to verify that the cross-section of the electric cables on the power point match the appliance's power rating.

Gas models or gas/electric models

ELECTRICAL CONNECTION

- If the hob is supplied without a power supply plug and therefore if you are not connecting directly to the mains, a standardized plug suitable for the load must be fitted.
- The power point must be connected to a suitable earth wiring, in conformity to current safety regulations.
- It is possible to connect the appliance directly to the mains supply by means of a heavy duty switch with 3 mm minimum distance between the contacts.

FEEDER SPECIAL CABLE SECTION Type "H05V2V2-F" resistance to temperatures of 90°C

220-240 V ac 3 x 0,75 mm²

220-240 V ac 3 x 1,5 mm² (for models with a rating of 1500 W at 230 V)

WARNING: If the power supply cable is damaged, it must be replaced only by an authorised service agent in order to avoid a hazard.

Replacing the power supply cable

- The supply cable must be replaced with a cable of the same type.
- The electrical cable must be connected to the terminal board following the diagram of fig. 3.1.

NOTE: The earth conductor must be left about 3 cm longer than the others.

The operations must be executed by a qualified technician.

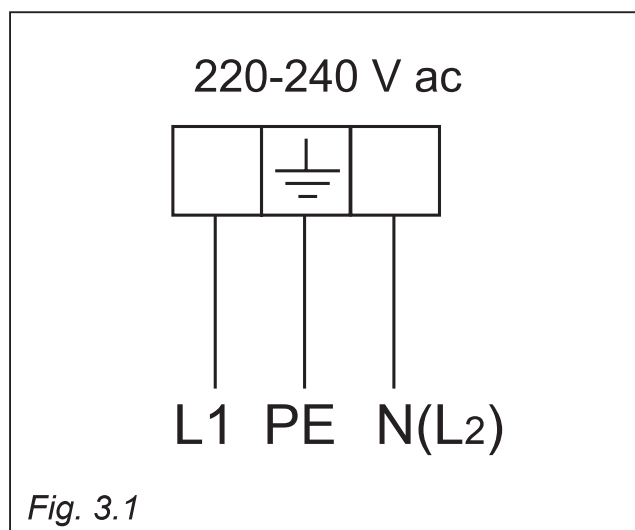

Fig. 3.1

4 electrical plates models

ELECTRICAL CONNECTION DETAILS

- The appliance must be connected directly to the mains supply by means of a heavy duty omnipolar switch with 3 mm minimum distance between the contacts.

WARNING: If the power supply cable is damaged, it must be replaced only by an authorised service agent in order to avoid a hazard.

The operations must be executed by a qualified technician.

To connect the feeder cable to the hob it is necessary to carry out the following operations:

- Unlock the 2 clips “B” and open the cover “C”.
- Unscrew the screw “D” and open completely the cable clamp “E” (figs. 3.4).
- Position the U bolts “F” onto terminal board “G” (figs. 3.4) according to the diagrams in fig. 3.3.
- Connect the phase and earth wires to terminal board “G” according to the diagrams in fig. 3.3.
- Strain the feeder cable and block it with cable clamp “E” (by screwing screw “D”).
- Close the cover “C” of the terminal board “G” and block it .

Important!

To connect the power supply cable **DO NOT** unscrew the screws fixing the cover plate “A” behind the terminal block.

FEEDER SPECIAL CABLE SECTION

“Type H05V2V2-F (resistance to temperatures of 90°C)

220-240 V ac 3 x 2.5 mm² (**)

380-415 V 2N ac 4 x 2.5 mm² (**)

380-415 V 3N ac 5 x 1.5 mm² (**)

(**) Connection with wall box connection.

- Diversity factor applied
- A diversity factor may be applied to the total loading of the appliance only by a suitably qualified person.

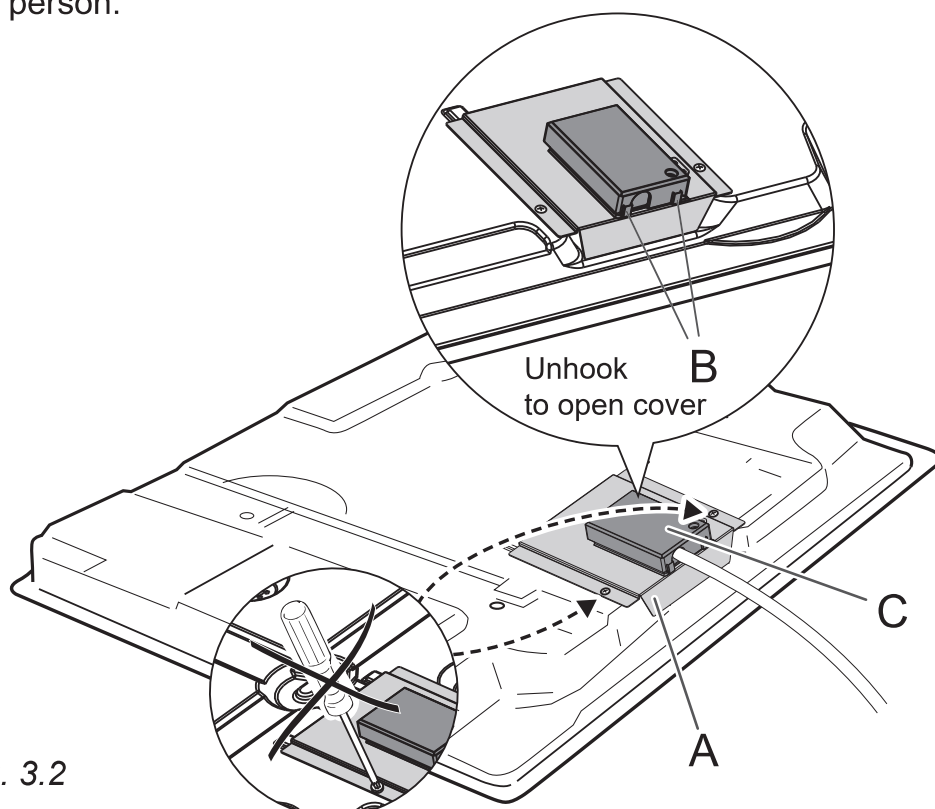
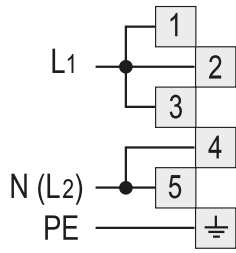
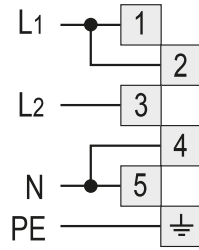

Fig. 3.2

220-240 V ac



380-415 V 2N ac



380-415 V 3N ac

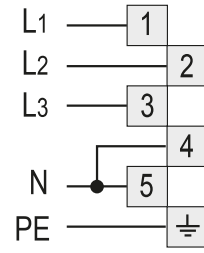

Fig. 3.3

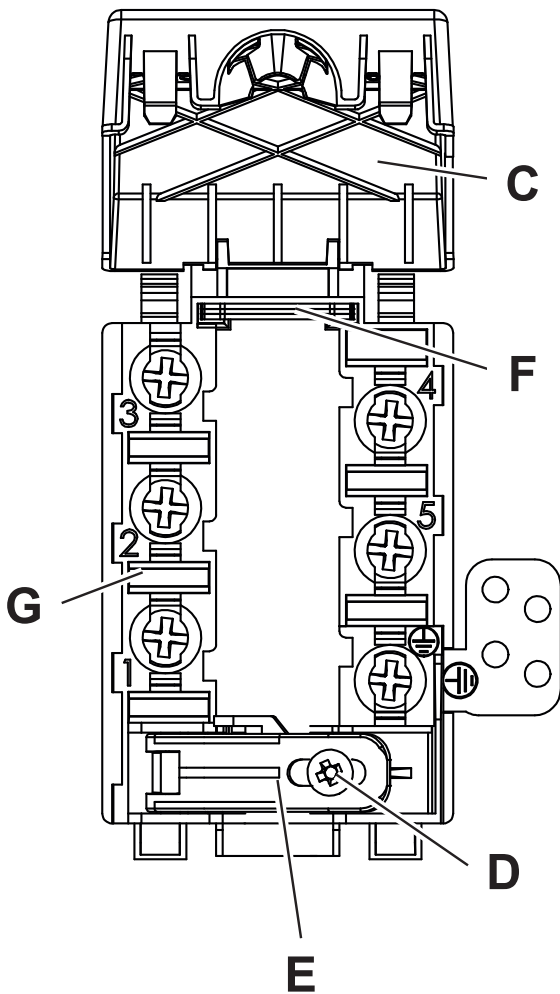

Fig. 3.4

Battery for electric ignition models

In some models the battery is the power supply for the electronic ignition of gas burners.

Batteries last on average for about two years (alkaline battery) depending on how often the electronic ignition is used.

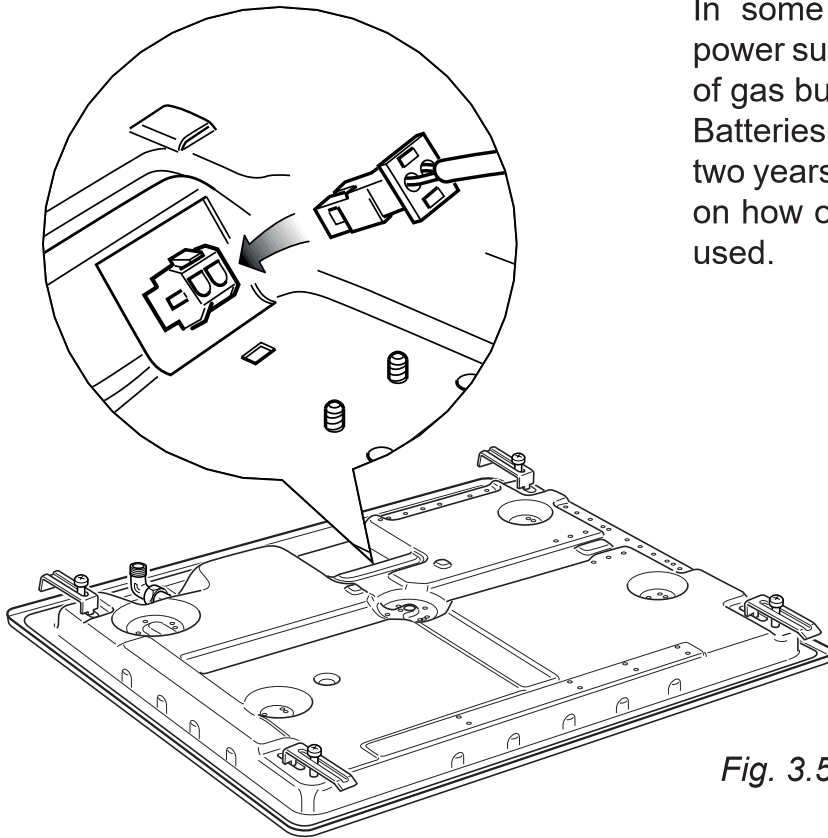

Fig. 3.5

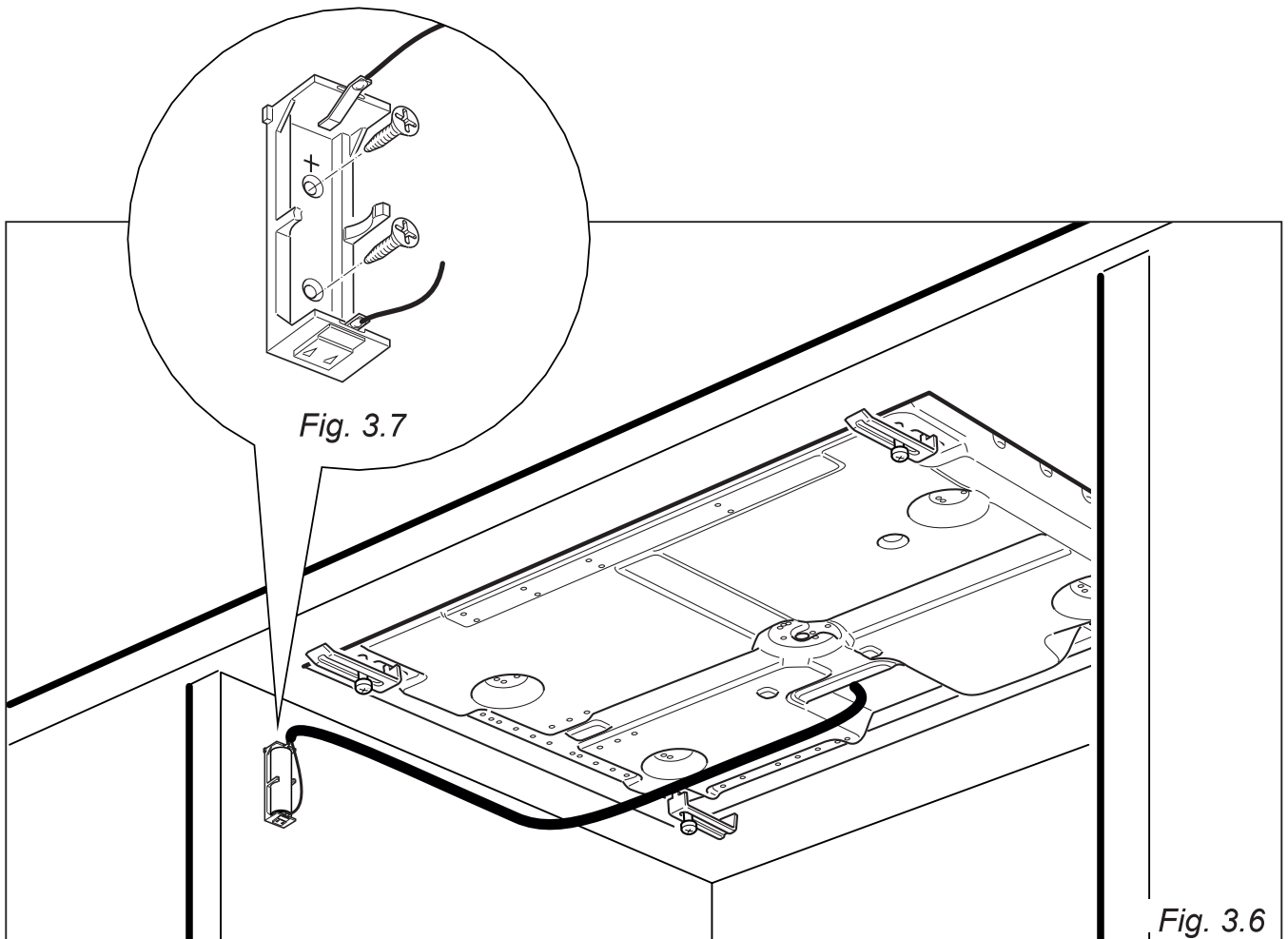

Fig. 3.7

Fig. 3.6

FITTING THE BATTERY IGNITION SUPPLY

- Remove pan supports and burners from the cooktop.
- Turn over the cooktop: be careful to lay on a soft surface so that it cannot be damaged.
- Connect the battery cable plug to the socket as indicated in figure 3.5.
- Fit the cooktop into the cabinet unit as described in the Installation chapter.
- Fix the battery holder to the cabinet unit (figures 3.6 - 3.7) with 2 suitable screws (not supplied). We suggest to position the support as per figure 3.6, on the left wall of the cabinet. Then fix the cable to the cabinet wall with suitable clamps (not supplied).

Important: do not secure the battery support to the hob casing.

- Insert a type AA battery (1.5 Volt) into the battery holder (fig. 3.8).

Important notes:

- Remove the battery if the cooking hob is not going to be used for a long time.
- If the battery leaks, replace it immediately. Avoid touching the leaked liquid and make sure it does not come into contact with clothes or other items.
- Clean the battery compartment carefully before installing the new one.
- **Note:** The battery is a potential source of danger for children. Keep them away.
- Dispose of flat batteries properly.

NOTES FOR BATTERY INSTALLATION OR REPLACEMENT:

- Only use a type AA 1.5 Volt battery.
- Check for correct polarity (fig. 3.8).

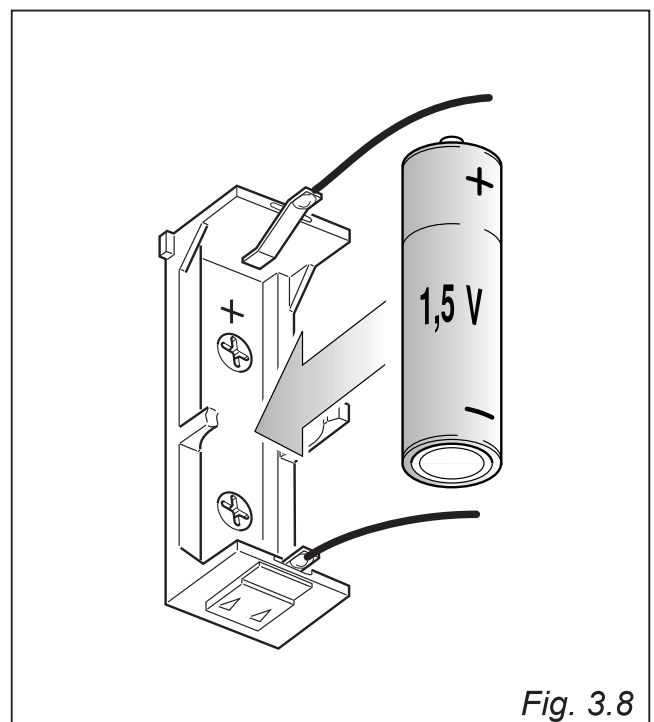

Fig. 3.8

Advice for the users

1

FEATURES AND TECHNICAL DATA

Fig. 1.1

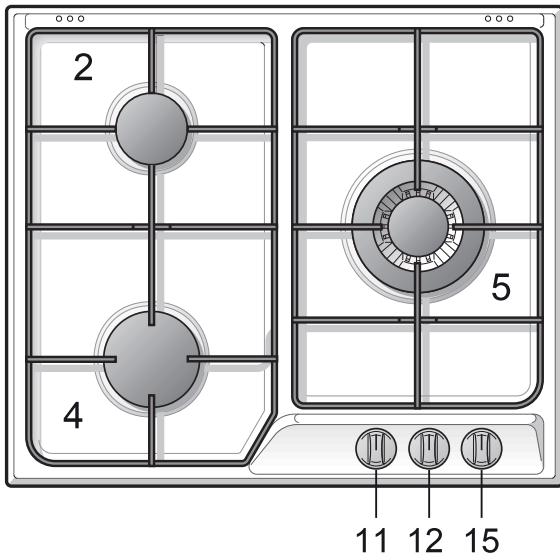

Fig. 1.2

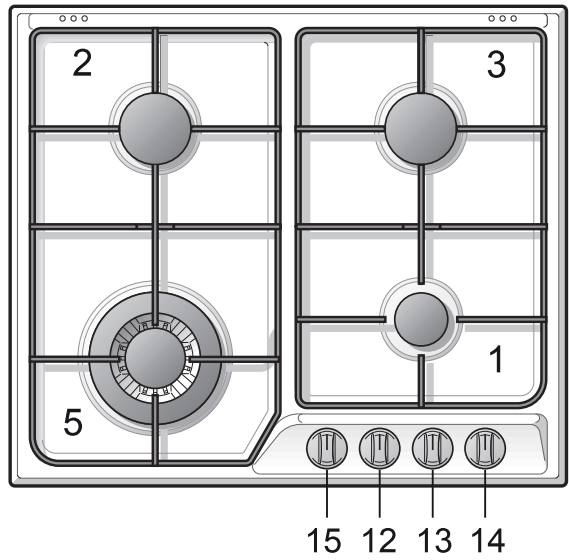

Fig. 1.3

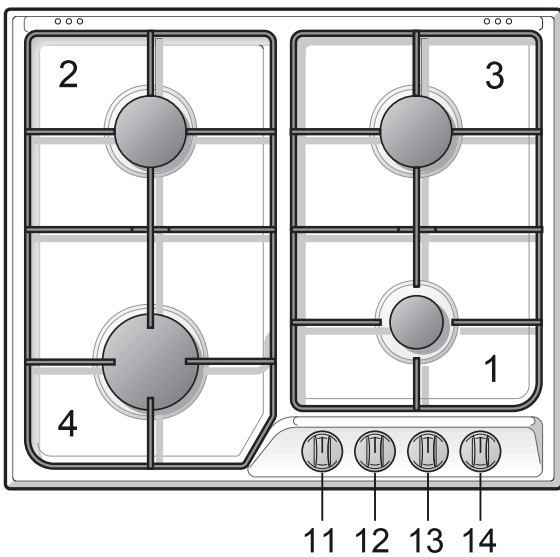

Fig. 1.4

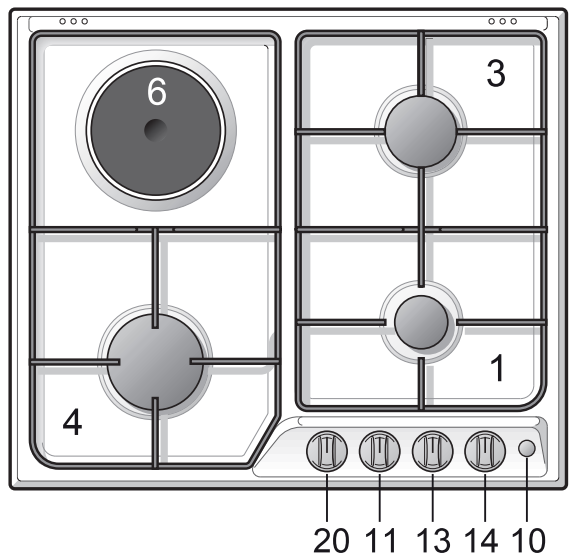
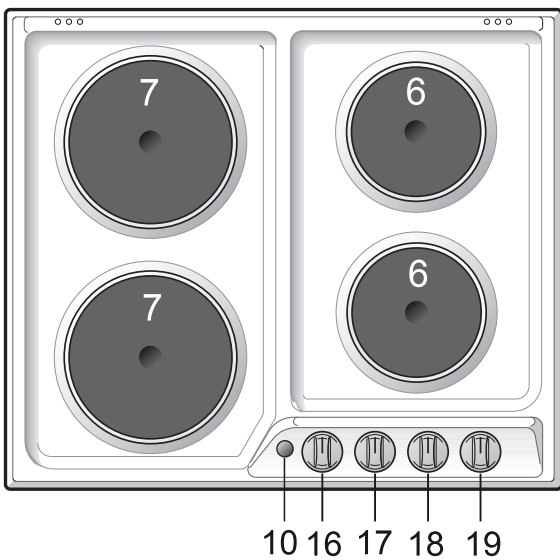

Fig. 1.5



NOTE:
The knobs and symbols may vary.

Caution!
Do not cover the hob with aluminium foils.

GAS BURNERS

1.	Auxiliary burner (A)	1,00 kW
2.	Semirapid burner (SR)	1,75 kW
3.	Semirapid burner (SR)	1,75 kW
4.	Rapid burner (R)	3,00 kW
5.	Triple-ring burner (TC)	3,50 kW
6.	Electric plate Ø 145 mm	Normal1000 W at 230 V Rapid (red dot)1500 W at 230 V
7.	Electric plate Ø 180 mm	Normal1500 W at 230 V Rapid (red dot)2000 W at 230 V

CONTROL PANEL DESCRIPTION

10. Electrical plate/s indicator light
11. Rapid burner control knob (4)
12. Semirapid burner control knob (2)
13. Semirapid burner control knob (3)
14. Auxiliary burner control knob (1)
15. Triple-ring burner control knob (5)
16. Front left electrical plate control knob (7)
17. Rear left electrical plate control knob (7)
18. Rear right electrical plate control knob (6)
19. Front right electrical plate control knob (6)
20. Rear left electrical plate control knob (6)

NOTE:

- The electric ignition is incorporated in the knobs.
- If the appliance has a safety valve system fitted (beside every burner there is a T-shaped probe, as in figs. 3.1 - 3.3 of page 34, not to be confused with the S-shaped electrode of the gas-lighter), the flow of gas will be stopped if and when the flame should accidentally go out.

CAUTION:

If the burner is accidentally extinguished, turn the gas off at the control knob and wait at least 1 minute before attempting to relight.

CAUTION:

Gas hobs produce heat and humidity in the environment in which they are installed. Ensure that the cooking area is well ventilated by opening the natural ventilation grilles or by installing an extractor hood connected to an outlet duct.

CAUTION:

If the hob is used for a prolonged time it may be necessary to provide further ventilation by opening a window or by increasing the suction power of the extractor hood (if fitted).

2 HOW TO USE THE COOKTOP

GAS BURNERS

Gas flow to the burners is adjusted by turning the knobs (illustrated in fig. 2.1 - 2.3) which control the valves.

Turning the knob so that the indicator points to the symbols printed on the panel achieves the following functions:

- full circle ● closed valve
- symbol  maximum aperture or flow
- symbol  minimum aperture or flow

- To reduce the gas flow to minimum, rotate the knob further anti-clockwise to point the indicator towards the small flame symbol.
- The maximum aperture position permits rapid boiling of liquids, whereas the minimum aperture position allows slower warming of food or maintaining boiling conditions of liquids.
- Other intermediate operating adjustments can be achieved by positioning the indicator between the maximum and minimum aperture positions, and never between the maximum aperture and closed positions.

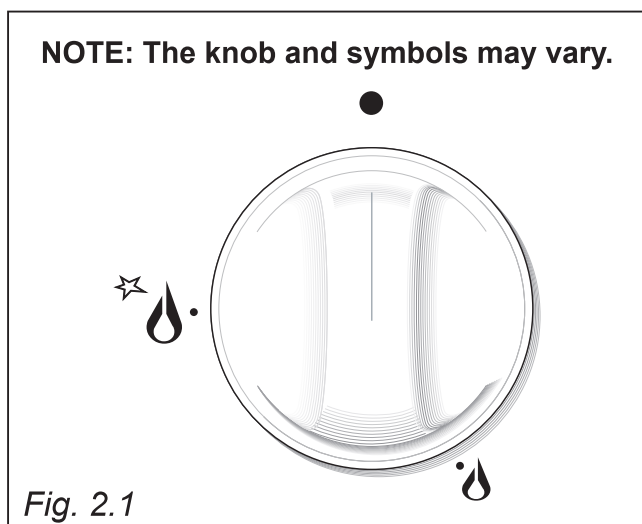

LIGHTING GAS BURNERS FITTED WITH SAFETY VALVE DEVICE

To ignite the burner, the following instructions are to be followed:

1. Press in the corresponding knob and turn counter-clockwise (fig. 2.2) to the full flame position marked by the “” symbol (fig. 2.1); hold the knob in until the flame has been lit. In the case of a mains failure light the burner with a match or lighted taper.
2. Wait for a few seconds after the gas burner has been lit before letting go of the knob (valve activation delay).
3. Adjust the gas valve to the desired position.

If the burner flame should go out for some reason, the safety valve will automatically stop the gas flow.

To re-light the burner, return the knob to the closed “” position, **wait for at least 1 minute** and then repeat the lighting procedure.

Note: If your local gas supply makes it difficult to light the burner with the knob set to maximum, set the knob to minimum and repeat the operation.

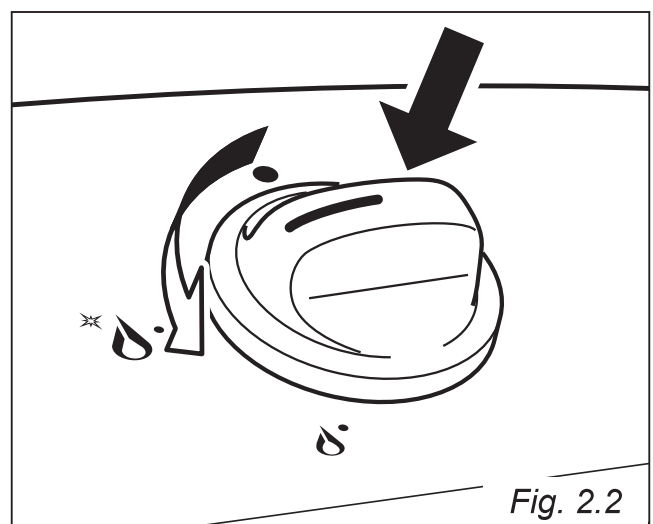

LIGHTING GAS BURNERS WITHOUT SAFETY VALVE DEVICE

To ignite the burner, the following instructions are to be followed:

1. Press in the corresponding knob and turn counter-clockwise (fig. 2.2) to the full flame position marked by the “

To turn it off, turn the knob towards the right, up to the safety click.

Note: If your local gas supply makes it difficult to light the burner with the knob set to maximum, set the knob to minimum and repeat the operation.

NOTE: The knob and symbols may vary.



Fig. 2.3

VERY IMPORTANT NOTE FOR THE MODELS WITHOUT SAFETY VALVE DEVICE

- WARNING
- TAKE SPECIAL CARE



The appliance must be supervised during the use of the gas burners.

If the burner flames should go out for some reason, the gas valve will continue to produce a flow of unburned gas through the burner. In that case, as soon as the flames should go out, turn the burner control knob to the “

If a burner does not remain lit in the minimum position, check the chapter “ADJUSTMENT OF THE MINIMUM OF THE TOP BURNERS” in the “ADVICE FOR THE INSTALLER” section.

If a burner does not remain lit in all the settings, check that the burner parts and the injector are dry and clean and that they are correctly in place.

CHOICE OF THE BURNER

On the control panel, near every knob there is a diagram that indicates which burner is controlled by that knob.

The suitable burner must be chosen according to the diameter and the capacity used. The burners and pans must be used in accordance with the following instructions:

DIAMETERS OF PANS WHICH MAY BE USED ON THE BURNERS

BURNERS	MINIMUM	MAXIMUM
Auxiliary (*)	12 cm	14 cm
Semi-rapid	16 cm	24 cm
Rapid	24 cm	26 cm
Triple-ring	26 cm	28 cm
Wok (**)	-	Max 36 cm

do not use pans with concave or convex bases

(*) with grill for small cookware: minimum diameter 6 cm (only for the models supplied with grill for small pans)

(**) Only for the models with triple ring burner and with wok pan adapter supplied

It is important that the diameter of the pot be suitable to the potentiality of the burner so as not to compromise the high output of the burners and therefore energy waste.

A small pot on a large burner does not give you a boiling point in a shorter amount of time since the capacity of heat absorption of a liquid mass depends on the volume and the surface of the pot.

CAUTION: Make sure the pans are central to the burner for maximum stability and greater efficiency.

Make sure the pans are not in contact with the control knobs, otherwise the flame could overheat the knobs and permanently damage them.

GRATE FOR SMALL PANS (Optional)

This grate is to be placed on top of the (smaller) auxiliary burner when using small diameter pans, in order to prevent them from tipping over.

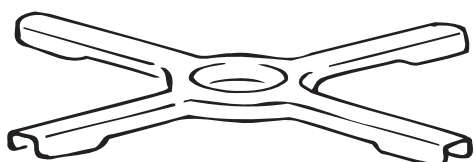

Fig. 2.4

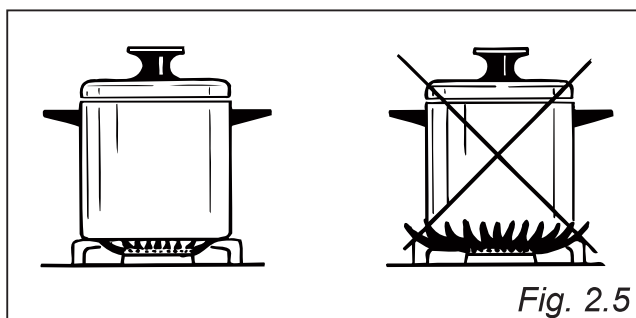

Fig. 2.5

SPECIAL WOK GRILLE - OPTIONAL - (models with triple-ring burner only)

(figs. 2.6a - 2.6b or 2.7a - 2.7b)

This special grille for woks should be placed over the pan-rest for the triple ring burner.

Warning:

- Using woks without this special grille may cause the burner to malfunction.
- Do not use the grille for ordinary, flat-bottomed saucepans.

IMPORTANT:

The special grille for wok pans **MUST BE PLACED ONLY** over the pan-rest for the triple-ring burner.

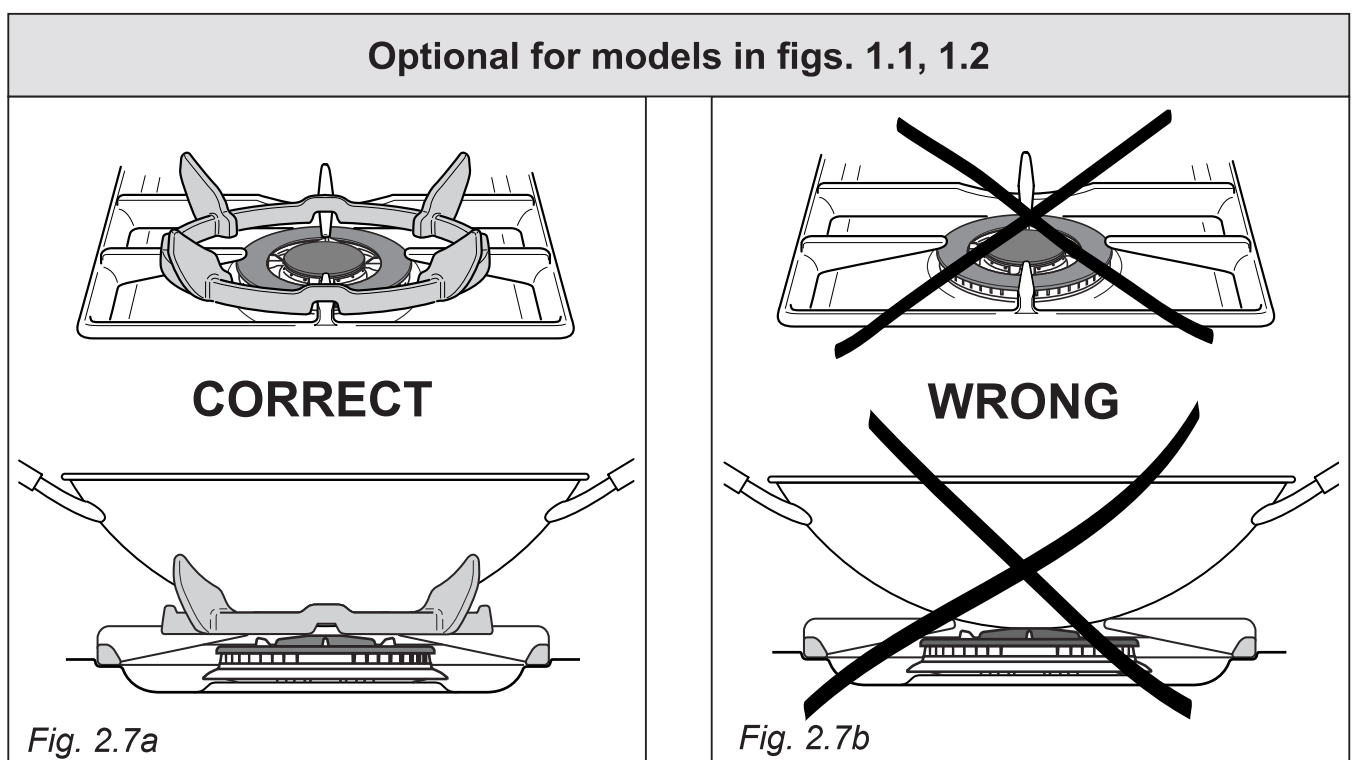
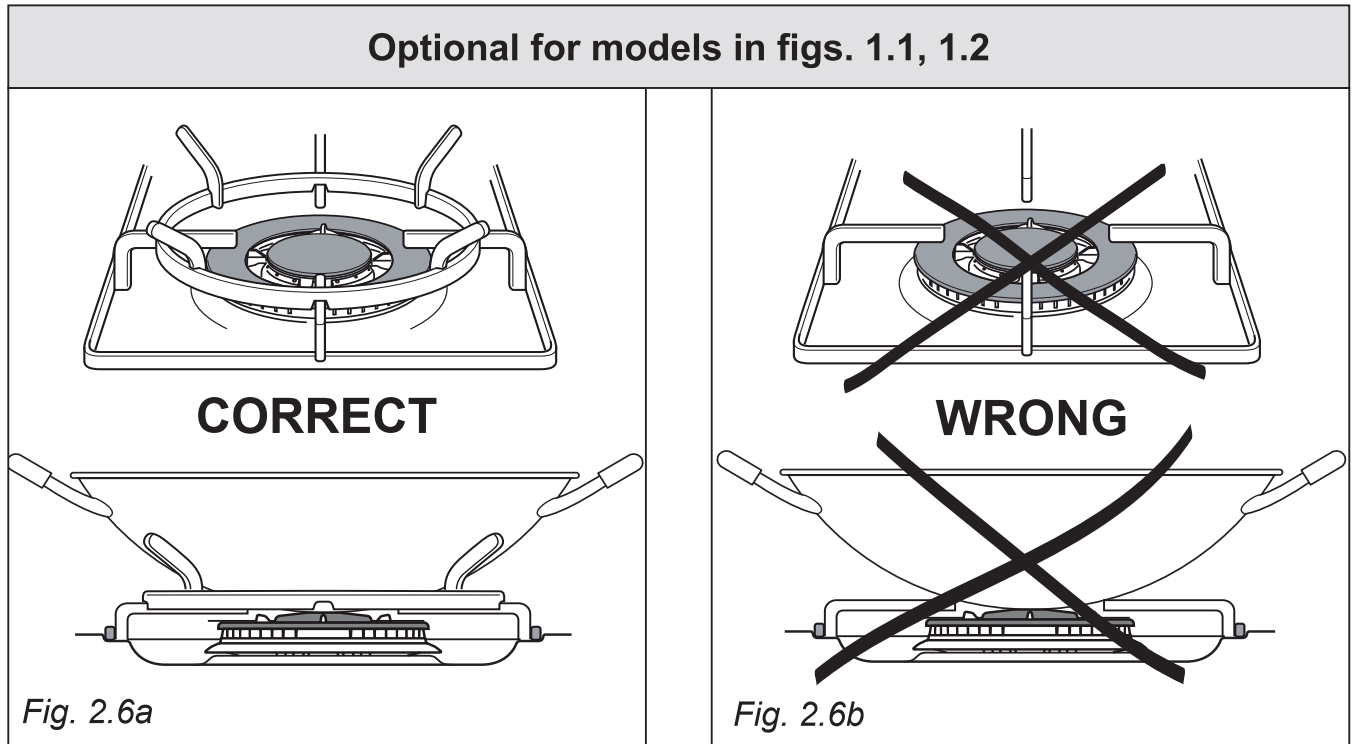

ELECTRIC HOTPLATE/S

NORMAL HOTPLATE

To switch on the normal hotplate, turn the knob (fig. 2.8) onto the desired position; the numbers 1 to 6 indicate the working positions with the increase of temperature according to the number.

Once boiling point has been reached, reduce the input according to the heating intensity desired, keeping in mind that the plate will continue to heat for 5 minutes after having been turned off.

RAPID HOTPLATE (red dot)

The control knob of the rapid hotplates is similar to that of a normal plate with 6 working positions (fig. 2.8).

The features of this plate, which is equipped with a heat limiter, allow:

- reaching the temperature rapidly;
- maximum exploitation of the input with flat bottom pots;
- the limitation of input in the case of unsuitable pots.

**Caution! the cooking hob becomes very hot during operation.
Keep children well out of reach.**

**NOTE:
The knobs and symbols may vary.**

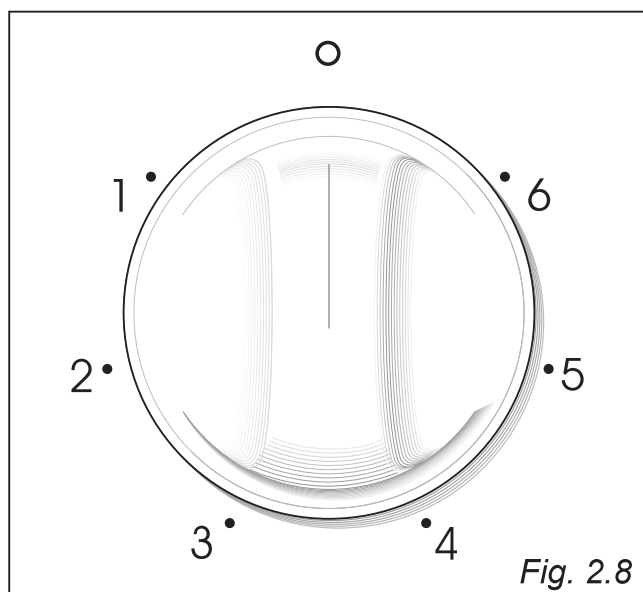

PROPER USE OF THE ELECTRIC HOTPLATE/S (fig. 2.9)

When the pan comes to the boil, turn the heat down to the level desired.

Remember that the hotplate will continue to produce heat for about five minutes after it has been turned off.

While using the electric hotplate, you must:

- avoid keeping it on without something on it;
- avoid pouring liquids on it while it is hot;
- use flat-bottomed (electric hotplate type) pots and pans only
- use cooking receptacles which cover as much of the surface of the hotplate as possible.
- to save electricity, use lids whenever possible.
- never cook food directly on the hotplate: always use a pan or suitable container.

An indicator light located close to the knob signals that the hotplate is operating.

Never cook food directly on the electric hotplates! Always use a saucepan or special container.

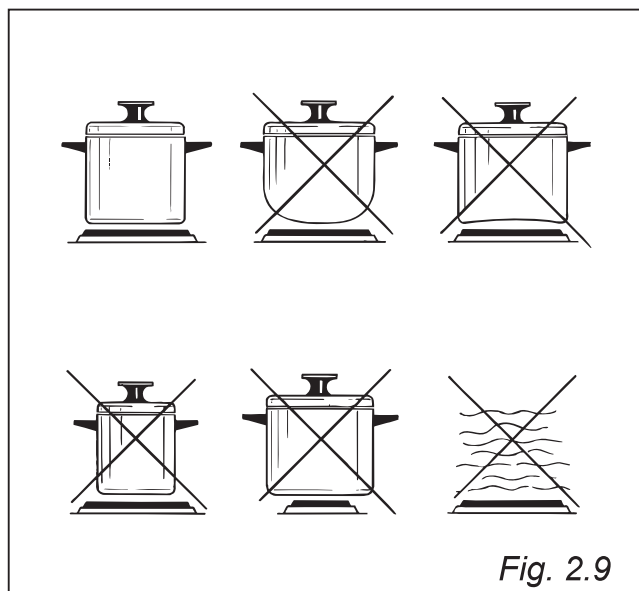

ELECTRIC HOTPLATE USAGE TABLE

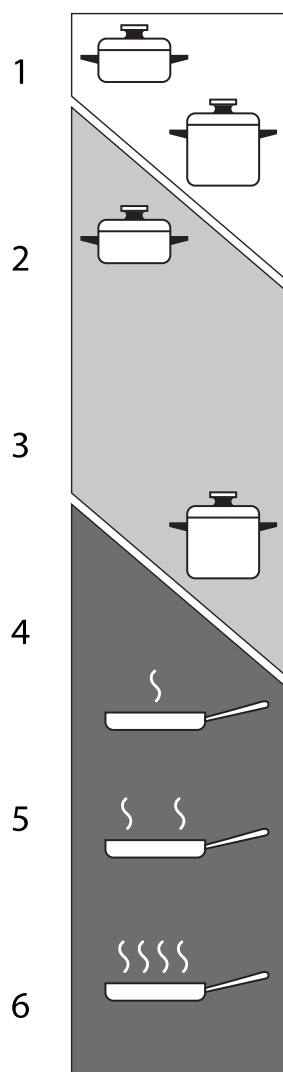

Heating



Cooking



Roasting-frying

Position of switch	TYPE OF COOKING
0	Switched OFF
1 2	For melting operations (butter, chocolate).
2	To maintain food hot and to heat small quantities of liquid (sauces, eggs).
3	To heat bigger quantities; to whip creams and sauces. (vegetables, fruits, soups).
3 4	Slow boiling, i.e.: boiled meats, spaghetti, soups, continuations of steam, cooking of roasts, stews, potatoes.
4	For every kind of frying, cutlets, uncovered cooking, i.e.: risotto.
4 5	Browning of meats, roasted potatoes, fried fish, omelettes, and for boiling large quantities of water.
6	Fast frying, grilled steaks, etc.

After a short period of use, experience will teach you which setting is the right one for your needs.

Fig. 2.10

3

CLEANING AND MAINTENANCE

GENERAL ADVICE

- **Before you begin cleaning you must ensure that the hob is switched off.**
- It is advisable to clean when the appliance is cold and especially when cleaning the enamelled parts.
- All enamelled surfaces have to be washed with soapy water or some other non-abrasive product with a sponge and are to be dried preferably with a soft cloth.
- Avoid leaving alkaline or acid substances (lemon juice, vinegar etc.) on the surfaces.
- **Do not use cleaning products with a chlorine or acidic base.**
- **Important: The use of suitable protective clothing/gloves is recommended when handling or cleaning of this appliance.**
- **Under no circumstances should any external covers be removed for servicing or maintenance except by suitable qualified personnel.**
- Clean surfaces with a damp cloth and use gentle, neutral cleaning products. Dry with a clean, dry cloth.
- **IMPORTANT:** Do not use any abrasive products (e.g. certain types of sponge) and/or aggressive products (e.g. caustic soda, products containing corrosive substances), which could cause irreparable surface damage.

WARNING:

When correctly installed, your product meets all safety requirements laid down for this type of product category.

However special care should be taken around the rear or the underneath of the appliance as these areas are not designed or intended to be touched and may contain sharp or rough edges, that may cause injury.

CLEANING ELECTRIC HOTPLATES (models with electric hotplate/s)

- Foods burned on the hot plates must always be cleaned dry.
- Do not use water, to avoid the formation of rust.
- After its use, pour a bit of oil onto the warm plate and rub with a cloth.

Important: The manufacturer declines all liability for possible damage caused by the use of unsuitable products to clean the appliance.

Attention! The appliance gets very hot, mainly around the cooking areas. It is very important that children are not left alone in the kitchen when you are cooking.

Do not use a steam cleaner because the moisture can get into the appliance thus make it unsafe.

COOKING HOBS WITH GLASS LID (optional)



Do not shut lid when burner alight.

ATTENTION

- ✓ Do not lower the glass lid when the gas burner are still hot and when the oven, installed below the cooking hob, is on or still hot.
- ✓ Do not lay on the glass lid hot pans and heavy kitchen utensils.
- ✓ Dry off any liquid which may have spilt on the cover before opening it.

ENAMELLED PARTS

- All the enamelled parts must be cleaned with a sponge and soapy water only or other non-abrasive products.
- Dry preferably with a microfibre or soft cloth.
If acid substances such as lemon juice, tomato conserve, vinegar etc. are left on the enamel for a long time they will etch it, making it opaque.

STAINLESS STEEL ELEMENTS

- Stainless steel parts must be rinsed with water and dried with a soft and clean cloth.
- For persistent dirt, use specific non-abrasive products available commercially or a little hot vinegar.
- **Note: regular use could cause discolouring around the burners, because of the high flame temperature.**

GAS TAPS

- Do not let cleaning products come into contact with the valves.
- Periodic lubrication of the gas taps must be carried out by specialist personnel only.
- In the event of operating faults in the gas taps, call the Service Department.

BURNERS AND PAN SUPPORTS

These parts must be cleaned using a sponge and soapy water or other suitable non-abrasive products. Dry with a soft cloth.

Warning! Not dishwasher safe.

After cleaning, the burners and their flame spreaders must be well dried and correctly replaced. It is very important to check that the burner flame spreader and the cap have been correctly positioned. Failure to do so can cause serious problems.

In the models with safety device, check that the probe "T" (figs. 3.1, 3.3) next to each burner is always clean to ensure correct operation of the safety valves.

Check that the electrode "S" (figs. 3.1, 3.3) next to each burner is always clean to ensure trouble-free sparking.

Both the probe and ignition plug must be very carefully cleaned.

Note: To avoid damage to the electric ignition do not use it when the burners are not in place.

Note: Continuous use may cause a change in the glaze around the burners and grids, corresponding to the areas exposed to the heat. This is a natural phenomenon and does not prevent the parts from working properly.

CORRECT REPLACEMENT OF THE AUXILIARY, SEMI-RAPID AND RAPID BURNERS

It is very important to check that the burner flame distributor "F" and the cap "C" have been correctly positioned (see figs. 3.1, 3.2) - failure to do so can cause serious problems.

CORRECT REPLACEMENT OF THE TRIPLE RING BURNER (models with triple-ring burner only)

The triple ring burner must be correctly positioned (see fig. 3.5); the burner rib must be enter in their logement as shown by the arrow (see fig. 3.3).

Then position the cap "A" and the ring "B" (figs. 3.4, 3.5).

The burner correctly positioned must not rotate (fig. 3.4).

Fig. 3.1

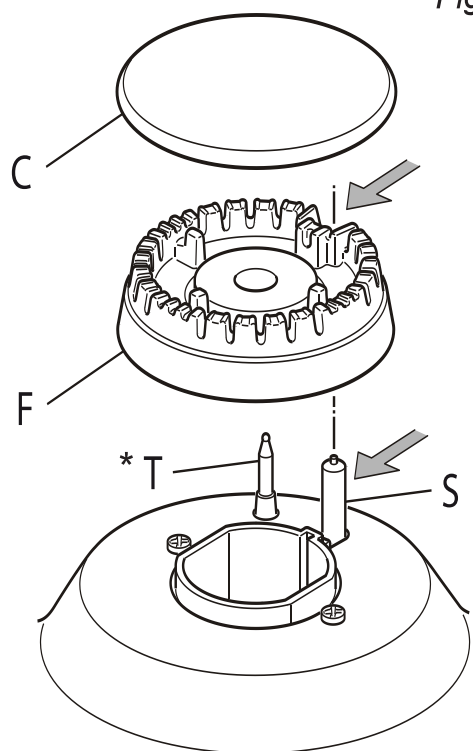

(*) Some models only

Fig. 3.2

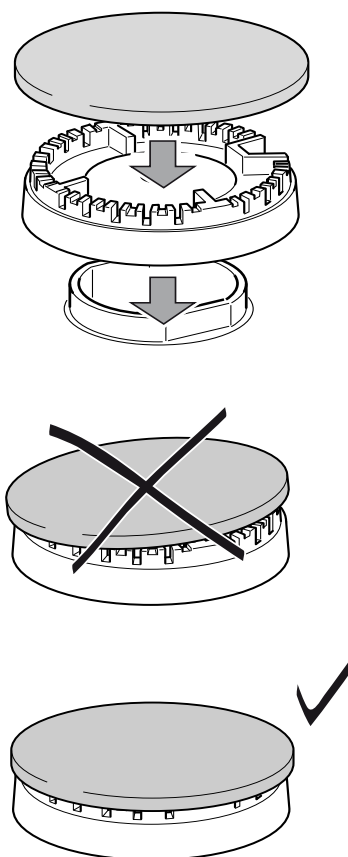
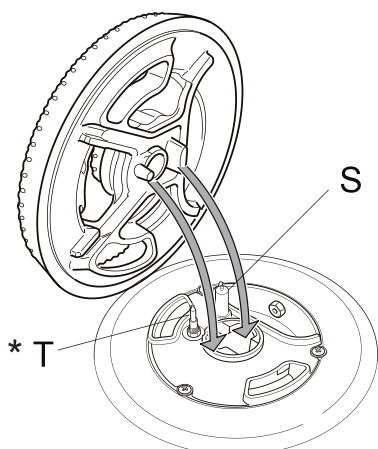

Fig. 3.3



(*) Some models only

Fig. 3.5

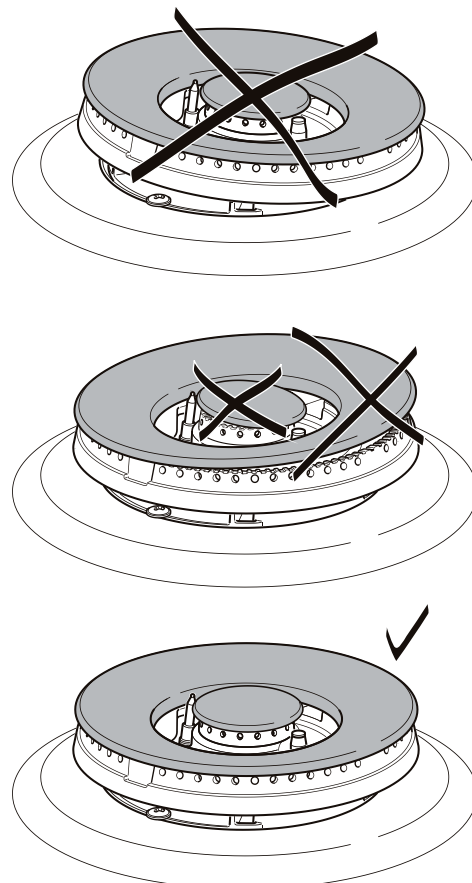
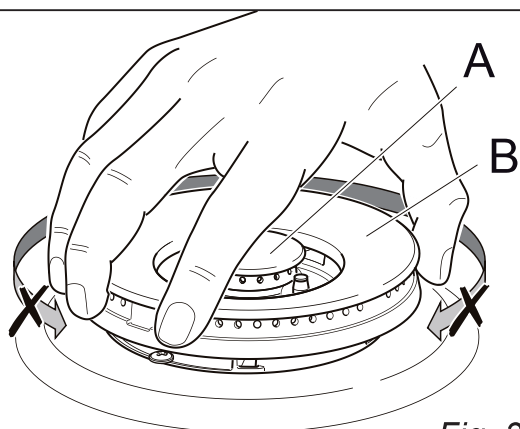



Fig. 3.4





The manufacturer cannot be held responsible for possible inaccuracies due to printing or transcription errors in the present booklet.

The manufacturer reserves the right to make all modifications to its products deemed necessary for manufacture or commercial reasons at any moment and without prior notice, without jeopardising the essential functional and safety characteristics of the appliances.